

8X ϕ .16in [4.0mm] ∇ .49in [12.4mm]
10-32 UNF - 2B ∇ .38in [9.7mm]

ϕ 2.20in [55.9mm]
Bolt Hole Circle

.629in [15.98mm]
Locating Key

3.50in [88.9mm]
Tie-Down Slots

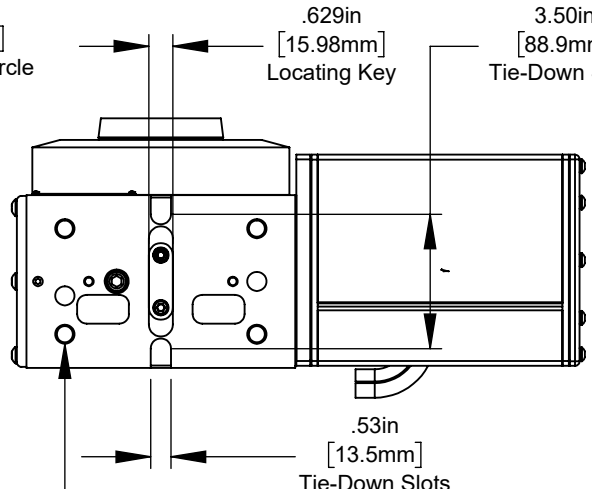
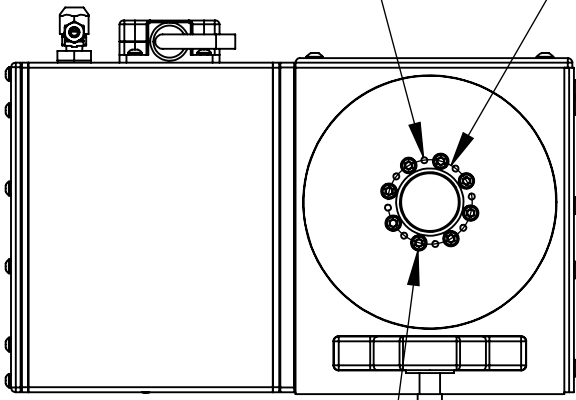

8X ϕ .27in [6.8mm] THRU ALL
 \sqsubset ϕ .41in [10.3mm] ∇ .26in [6.5mm]

All dimensions based on stackup of sheetmetal, subject to variation of 1/2" (13 mm)

